

API Steel Gate valve CLASS 150LB

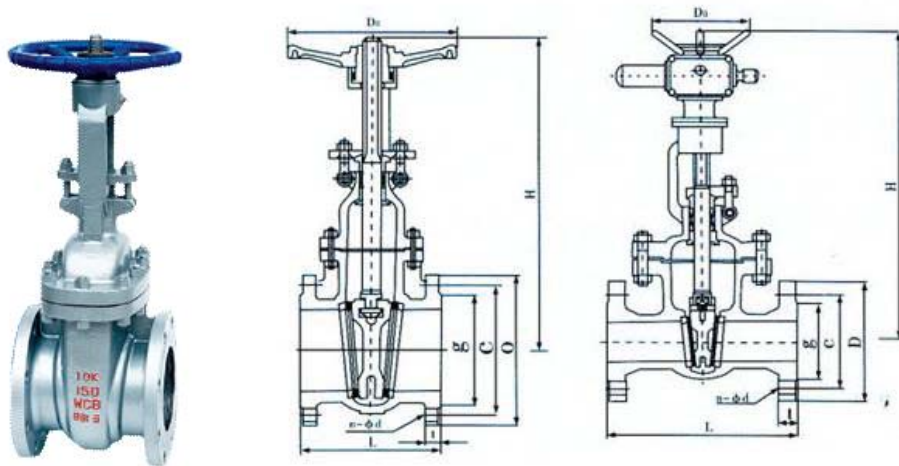

Administer Standard

Design And Manufacture	Face to face / End to end	Flange Dimension	Butt welding dimension	Pressure Temperature Rating	Inspection And Test
API 600, API 6D	ANSI B16.10	ANSI B16.5	ANSI B16.25	ANSI B16.34	API 598

Administer Standard

Design And Manufacture	Face to face / End to end	Flange Dimension	Butt welding dimension	Pressure Temperature Rating	Inspection And Test
API 600, API 6D	ANSI B16.10	ANSI B16.5	ANSI B16.25	ANSI B16.34	API 598

Pressure Test

PN(Lb) Nominal Pressure	Shell Test		Water Seal Test		Air Seal' Test	
	Mpa	Lb/fin ²	Mpa	Lb/fin ²	Mpa	Lb/fin ²
150	3.1	450	2.2	315	0.5-0.7	60-100
300	7.8	1125	5.6	815		
600	15.3	2225	11.2	1630		
900	23.1	3350	16.8	2440		
1500	38.4	5575	28.1	4080		

Main Part Materials and Property

Body	Stem	Sealing Face	Sealing Shim	Packing	°C Working Temperature	Suitable Medium
Cover						
Disc						

WCB	2Cr13	With Body Material	Enhanced	Flexible Graphite 13Cr 1Cr13 / Flexible Graphite SFB-2 08 Soft Steel F304 F316 F304L F316L	Flexible Graphite Enhanced Flexible graphite SFB / 260 SFP / 260 PTFE	≤425	Water Steam Petroleum Products
WCI			13Cr			≤450	
WC6	38CrMoA1		STL			≤540	
WC9	25Cr2MoV					≤570	
C5 C12						≤540	
CF8	304		PTFE				
CF3	316						
CF8M	304L		Nylon				
CF3M	316L					≤200	Nitric acid Acetic acid Urea acid

API Steel Gate valve	H	Z40	150Lb-1500Lb
	Y		
	W		

Dimensions And Weights(mm and inches :)

CLASS 150LB

DN	401	50	65	80	100	125	150	200	250	300	350	400	450	500	600	650	700
NPS	1/2	2	2 1/2	3	4	5	6	8	10	12	14	16	18	20	24	26	28
L(RF)	165	178	190	203	229	254	267	229	330	356	381	406	432	457	508	559	610
	6.5	7	7.5	8	9	10	10.5	11.5	13	14	15	16	17	18	20	22	24
H	390	400	490	508	585	740	773	955	1160	1375	1569	1765	1978	2219	2611	2800	3000
	15.4	15.8	19.3	20	23	29.2	30.4	37.7	45.8	54.2	61.8	69.5	77.9	87.4	102.4	114.2	121.9
D0	200	200	200	250	300	300	350	350	400	450	500	600	700	680	720	720	780
	8	8	8	10	12	12	14	14	16	18	20	24	24	27	28.4	28.4	30.5
wt(Kg)	18	19	24	32	49	59	78	116	190	268	345	500	610	900	1135	1500	2100

CLASS 300LB

DNNPS	401	50	65	80	100	125	150	200	250	300	350	400	450	500	600
	1/2	2	2 1/2	3	4	5	6	8	10	12	14	16	18	20	24
L(RF)	190	216	241	283	305	381	403	419	457	502	762	838	914	991	1143
	7.5	8.5	9.5	11.2	12	15	15.9	16.5	18	19.8	30	33	36	39	45
H	450	470	525	533	633	800	805	1024	1232	1460	1645	1841	1988	2238	2623
	17.8	18.5	20.8	21	24.9	31.5	31.8	40.3	48.5	57.5	64.8	72.5	78.3	86.4	102.5
D0	200	200	200	300	300	350	350	400	450	500	600	600	680	750	800
	8	8	8	12	12	14	14	16	18	20	24	24	27	28.4	31.5
wt(Kg)	23	26	34	47	68	100	130	200	340	430	640	1100	1420	1600	2100

CLASS 600LB											
DN NPS	40 11/2	50 2	65 21/2	80 3	100 4	150 6	200 8	250 10	300 12	350 14	400 16
L(RF)	241 9.5	292 11.5	330 13	356 14	432 17	559 22	660 26	787 31	838 33	889 35	991 39
H	470 18.5	474 18.8	530 20.9	547 21.5	703 27.8	913 36	1077 42.4	1276 50.1	1490 58.8	1658 65.3	1865 73.4
D0	200 8	250 10	250 10	300 12	350 14	450 18	500 20	600 24	680 27	750 30	
wt(Kg)	30	37	54	70	110	220	400	600	780	1280	1620
CLASS 900LB											
DN NPS	15 11/2	25 1	40 11/2	50 2	65 21/2	80 3	100 4	150 6	200 8	250 10	300 12
L(RF)	216 8.5	254 10	305 12	368 14.5	419 16.5	381 15	457 18	610 24	737 29	838 39	965 38
H	300 11.8	380 15	490 19.3	620 24.5	705 27.8	695 27.3	825 32.5	1065 42	1318 52	1540 60.6	1840 72.5
D0	100 3.9	200 8	250 9.8	300 12	350 14	350 14	400 16	500 20	600 24	750 30	
wt(Kg)	26	30	34	95	155	128	192	378	635	900	1550
CLASS 1500LB											
DN NPS	15 11/2	25 1	40 11/2	50 2	65 21/2	80 3	100 4	150 6	200 8	250 10	300 12
L(RF)	216 8.5	254 10	305 12	368 14.5	419 16.5	470 18.5	546 21.5	705 27.8	832 32.8	991 39	
H	300 11.8	380 15	490 19.3	695 27.4	755 27.8	770 30.3	872 348	1092 43	1400 55.1	1600 63	
D0	100 3.9	200 8	250 9.8	400 16	400 16	400 16	500 20	600 24	750 30		
wt(Kg)	27	30	34	95	128	181	275	627	1000	2200	